



Rewarding Learning

ADVANCED  
General Certificate of Education

Centre Number

--	--	--	--	--

Candidate Number

--	--	--	--

# Technology and Design

Assessment Unit A2 1

*assessing*

Systems and Control or  
Product Design

[ATE11]

Assessment

**MV18**

Assessment Level of Control    Tick the relevant box (✓)

**Time**

Controlled Conditions	<input type="checkbox"/>
Other	<input type="checkbox"/>

2 hours, plus your additional time allowance.

## Instructions to Candidates

Write your Centre Number and Candidate Number in the spaces provided at the top of this page and on the A3 pro forma answer pages provided.

Answer **both** questions in **either** Section A, B or C.

Answer to Questions **4(d), 4(e), 5(h) and 6(i)(i) and (ii)** should be made on the A3 pro forma answer pages provided.

At the conclusion of the examination, attach the A3 pro forma answer pages securely to this paper with the treasury tag supplied.

## Information for Candidates

The total mark for this paper is 80.

Quality of written communication will be assessed in Question **1(c), 3(a)(iii) and 5(g)**.

Figures in brackets printed at the end of each question indicate the marks awarded to each question or part question.

# Section A

## Electronic and Microelectronic Control Systems

Answer **both** questions in this section.

- 1 (a) Some food packaging processes make use of electronic sensors.  
**Fig. 1** shows how a strain gauge can be used as a sensor to check the weight of a food can on a production platform.

**Fig. 1**

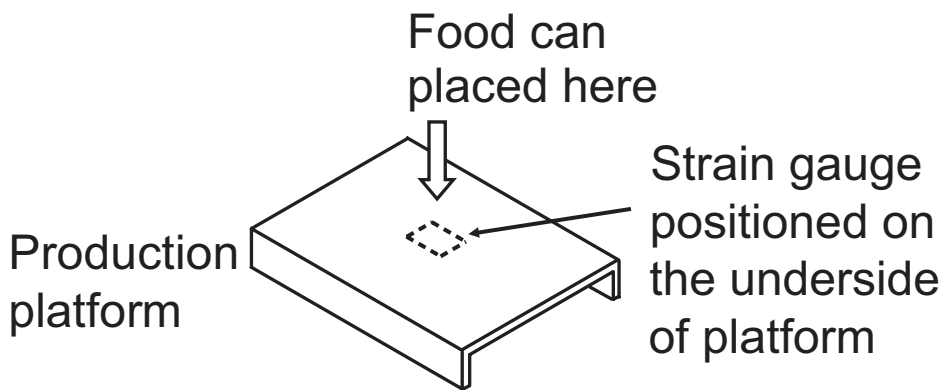

- (i) State the principle of operation of a strain gauge.  
[1 mark]

---

---

- (ii) The strain gauge labelled in **Fig. 1** has an active and a passive axis. Explain the main difference between these two axes. [2 marks]

---

---

(iii) The strain gauge in **Fig. 1** is to be connected as part of a Wheatstone bridge arrangement in order to give a differential voltage. Draw a circuit diagram to represent a Wheatstone bridge arrangement which includes a strain gauge and label the differential voltage. [3 marks]

(iv) When a food can is set on the production platform in **Fig. 1**, the differential voltage from the Wheatstone bridge is 0.025 V. Calculate the required gain for a differential amplifier that will give an output voltage of 5 V when a can is set on the platform. [2 marks]

Answer \_\_\_\_\_

(b) When cans from a production process need to be counted, a binary counter may be used to make a suitable circuit. A 4 bit binary counter is shown in **Fig. 2** where output QA is the least significant bit. Graphs representing the clock input and the 4 outputs from the binary counter are also shown. However, only the graphs for the clock input, QB and QD outputs have been completed.

**Fig. 2**

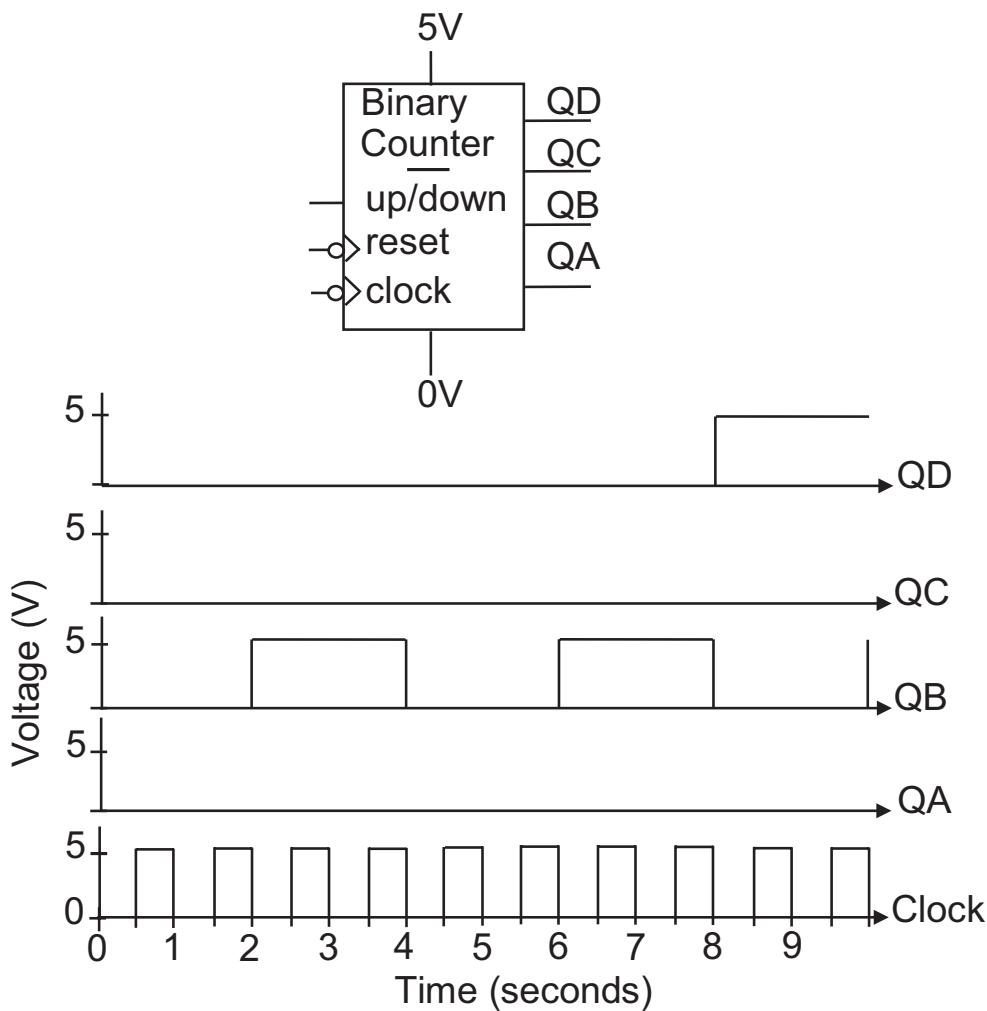

- (i) State the decimal equivalent for the 4 bit binary number **0101**. [1 mark]

Answer \_\_\_\_\_

- (ii) The binary counter shown in **Fig. 2** can be considered as a frequency divider. Briefly explain what is meant by the term 'frequency divider' when referring to a binary counter. [2 marks]

---

---

---

- (iii) From the graphs in **Fig. 2**, determine the clock frequency for the binary counter. [1 mark]

Answer \_\_\_\_\_ Hertz

- (iv) Complete the graphs for binary counter outputs QA and QC on **Fig. 2**. [2 marks]





(d) **Fig. 3** shows a block diagram and associated drawing of part of a canned food production line. A conveyor, which is moved by a 24 volt DC motor, feeds the cans into a lift tray in batches of 12. The cans are detected on the conveyor by an overhead detection unit that produces a 5 millisecond pulse each time a can passes under it. The lift, which is also moved by a 24 volt DC motor, takes the batch of cans to another level of the production line.

**Fig. 3**

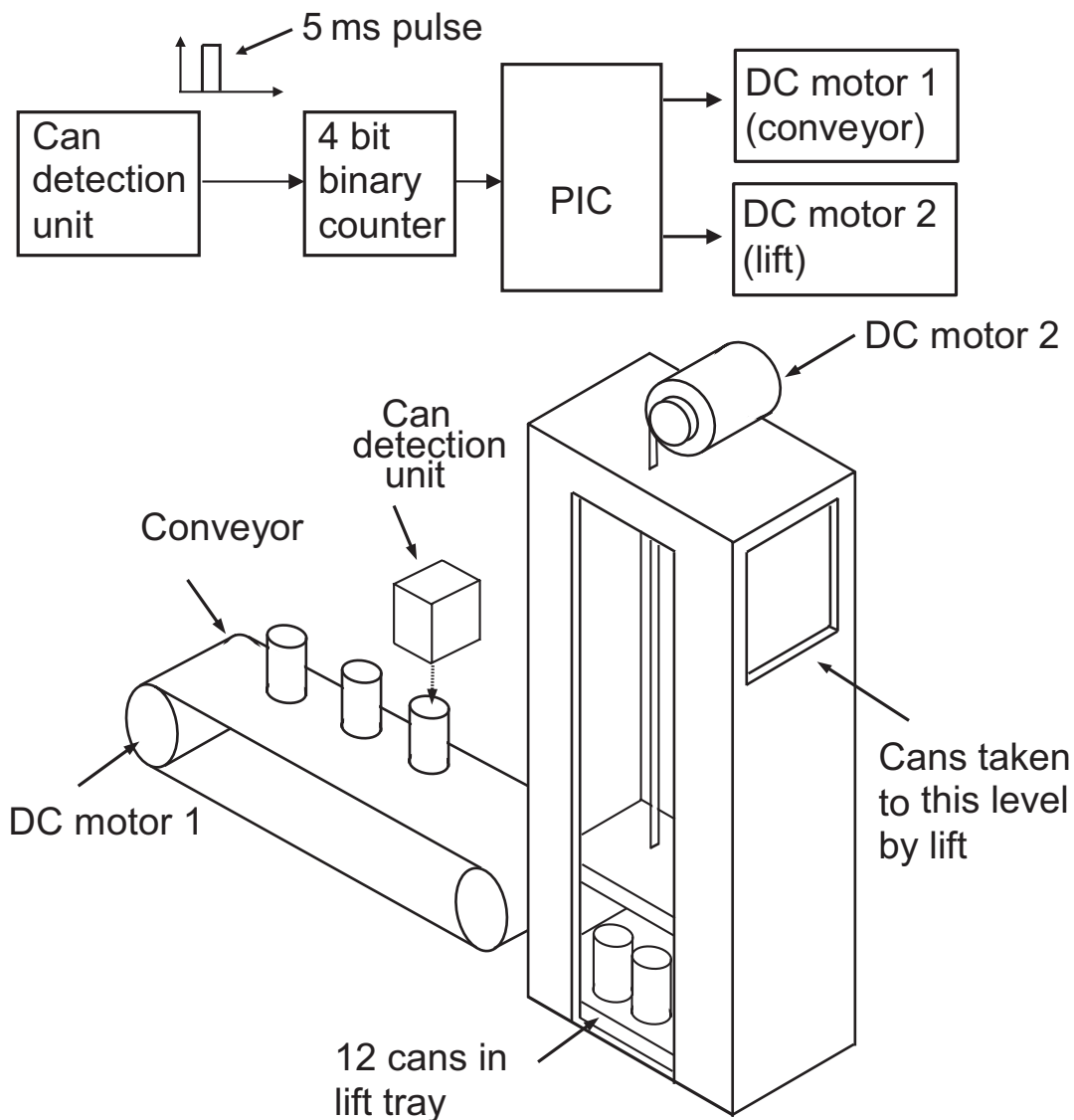

- (i) DC motors are frequently chosen over other motors to move conveyors on production lines.

Describe **one** main characteristic of a DC motor that makes it suitable for moving a conveyor. [2 marks]

---

---

- (ii) The can detection unit shown in **Fig. 3** generates a 5 volt pulse with a duration of 5 milliseconds each time a can passes underneath it. Draw and annotate a circuit that could detect a can and generate a 5 millisecond pulse without the can coming into physical contact with the detector unit. (If your circuit is PIC based, you must provide an appropriate flow chart.) [5 marks]

**(iii)** Draw an annotated electronic circuit diagram with associated flow chart program on the following pages to control the system shown in **Fig. 3** as follows: [10 marks]

- Switch the DC motor on for the conveyor to move the cans.
- Increment the binary counter (from **Fig. 2**) each time a can passes underneath the detection unit.
- Stop the conveyor motor and reset the counter when 12 cans have been detected.
- Switch on the DC motor for the lift until it reaches an upper limit switch where it remains for 2 seconds for the batch to be removed.
- Lower the lift for 10 seconds until it hits a lower limit switch at which point the conveyor moves again.

(Note: You are not required to redraw the can detection unit circuit and may assume that appropriate pulses from it are available when required.)

**Blank page**

**(Answer pages for Question 1(d)(iii) are  
overleaf on pages 12 and 13)**

## Answer pages Question 1(d)(iii)

**Answer pages Question 1(d)(iii) continued.**

- 2 (a) A microswitch to be used in the design of a flood warning system is shown in **Fig. 4** along with its accompanying circuit symbol.

**Fig. 4**

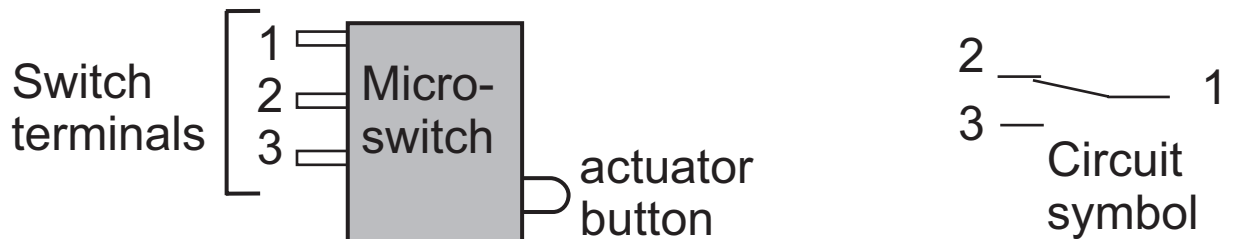

- (i) Show, with the aid of a circuit diagram, how the microswitch in **Fig. 4** could be used to produce a 5 volt logic 'high' when the actuator button is operated. Assume that the circuit symbol in **Fig. 4** depicts the microswitch in the unoperated condition. [2 marks]

(ii) One drawback when using logic signals from microswitches is that unwanted signals can be caused by the contacts which 'bounce' when operated. Explain, with the aid of an annotated circuit, a **non PIC based solution** to this problem. [5 marks]

(b) Part of a flood warning system is shown in **Fig. 5**. overleaf on page 16. When the flood water enters the flood chamber, the float will move up the guide bar and operate the microswitches Sw1, Sw2 and Sw3. The microswitches, which give a logic '1' when operated, are connected to a logic circuit which will then control three different coloured warning lamps under the following conditions:

- The green lamp will illuminate if Sw1 on its own is operated.
- The amber lamp will illuminate if Sw1 AND Sw2 are operated OR Sw2 on its own is operated.
- The red lamp will illuminate if Sw2 AND Sw3 are operated OR if Sw3 on its own is operated.
- The red lamp will also illuminate if no switches are operated (as the float will be above Sw3).

**Fig. 5**

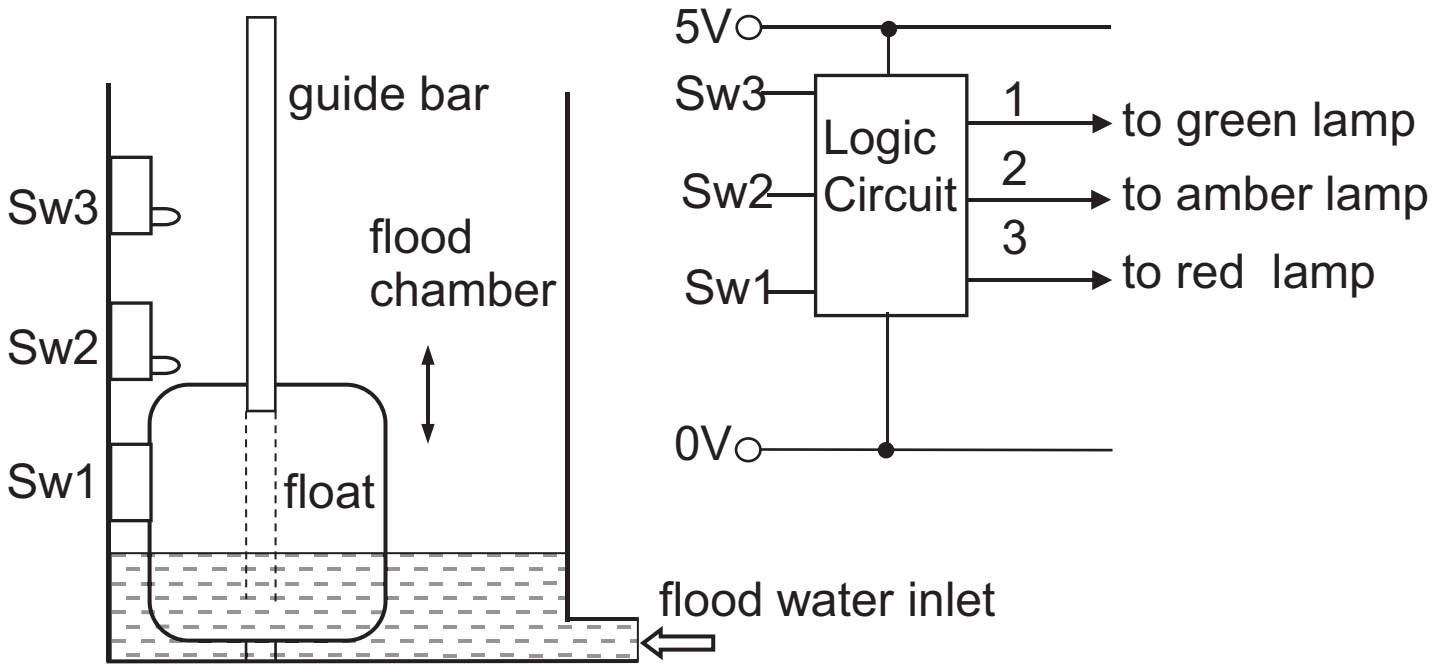

- (i) Complete the truth table in **Fig. 6** below to show the logic inputs Sw1, Sw2 and Sw3 from **Fig. 5** and the outputs for the red, amber and green lamps.  
[3 marks]

**Fig. 6**

Sw3	Sw2	Sw1	red	amber	green
0	0	0			
0	0	1			
0	1	0			
0	1	1			
1	0	0			
1	0	1	0	0	0
1	1	0			
1	1	1	0	0	0

- (ii) Complete Karnaugh maps in the grids below to determine minimised logic expressions for the red and amber lamps. [2 marks for each]

Minimised expression red \_\_\_\_\_

Minimised expression amber \_\_\_\_\_

- (iii) Draw a logic circuit that will produce the required outputs for the red, amber and green lamps for the flood warning system. [3 marks]

(iv) The lamps used in the flood warning system in **Fig. 5** are each specified to operate at 12 volts with a power dissipation of 10 Watts.

State **two** potential safety hazards associated with the use of the 12 volt lamp and associated driving circuit, and then describe **one** main procedure that can be implemented to minimise **one** of these hazards. [2 marks for each]

Safety hazards \_\_\_\_\_

\_\_\_\_\_

Safety procedure \_\_\_\_\_

\_\_\_\_\_

\_\_\_\_\_

(c) LED displays are considered to be more energy efficient than traditional lamps, and one such LED replacement unit for a lamp is shown in **Fig. 7**. The replacement unit consists of 12 LEDs arranged in a pattern and internally connected as shown. Each LED in the replacement unit operates at a forward voltage of 2V and a maximum current of 20 mA

**Fig. 7.**

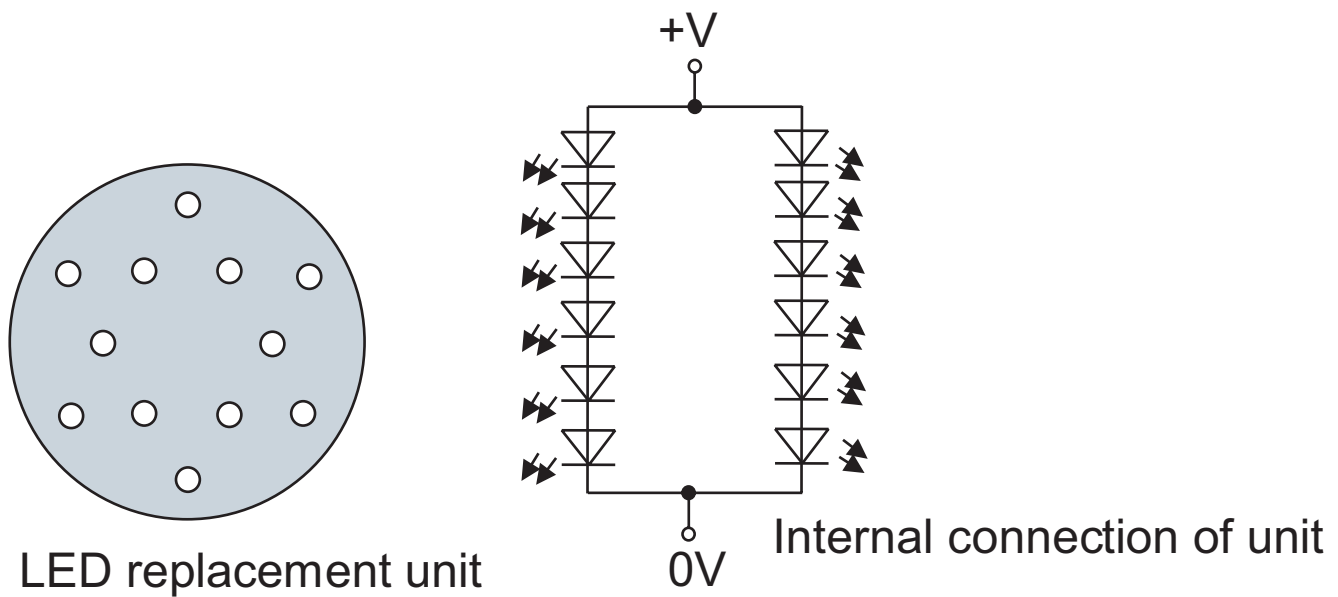

- (i) It has been suggested that a protective resistor may not be required if the LED replacement unit in **Fig. 7** is to be operated from an appropriate 12 volt supply. Show by calculation how you would determine if a protective resistor is required. [2 marks]

- (ii) Calculate the difference in power dissipation between the 12 volt lamp referred to in (b)(iv) and the proposed LED replacement unit shown in Fig. 7. [2 marks]

Answer \_\_\_\_\_ W

- (d) The logic circuit for the flood warning system shown in Fig. 5 is to be replaced with an updated PIC based circuit that will check the three float microswitches (Sw1, Sw2 and Sw3) and control three LED replacement units (red, amber and green) with the same control functions as stated in part (b).

In addition, a 12 volt sounder unit is to be added to the system to provide an audible warning, as well as a mute switch to allow the user to disable or enable the sounder when required.

- (i) Draw a block/system diagram to represent the proposed updated system. [3 marks]

(ii) The updated PIC based system could make use of an interrupt command in its flow chart program. Explain **one main** advantage of using an interrupt command when writing a flow chart program.  
[2 marks]

---

---

---

(iii) Draw an annotated circuit diagram and associated flow chart program for the updated flood warning system (on the following pages) to meet the following criteria: [10 marks]

- Read the digital inputs from the three microswitches once every 2 seconds. (There is no requirement to include a 'debounce' method.)
- Control three 12 volt LED units of the type shown in **Fig. 7**.
- Control a 12 volt sounder to operate when the red LED output is active.
- Make the sounder repeatedly sound for a period of 0.5 seconds every 2 seconds when the red LED output is active.
- Allow the user to mute the sounder or enable the sounder by means of a switch.

## Answer pages Question 2(d)(iii)

**Answer pages Question 2(d)(iii) continued.**

## Section B

### Mechanical and Pneumatic Control Systems

Answer **both** questions in this section.

- 3 (a) (i) Outline **two** main safety procedures used to minimise the risks to a user being injured by compressed air entering the bloodstream.  
[1 mark for each]

1. \_\_\_\_\_

\_\_\_\_\_

2. \_\_\_\_\_

\_\_\_\_\_

(ii) Crankshafts, similar to the one shown in **Fig. 8**, control the movement of the pistons in a combustion engine. Using an annotated sketch, outline the main features of a thrust bearing and explain why it would be selected in preference to a plain bearing for supporting the crankshaft shown in **Fig. 8**.

**Fig. 8**

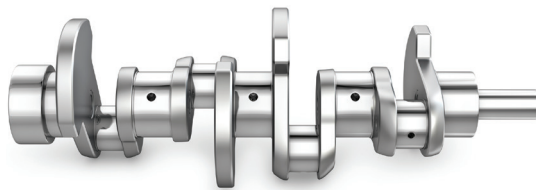

Annotated sketch [3 marks]

Explanation [2 marks]

---

---

---

---

(iii) Bicycles similar to the ones shown in **Fig. 9** and **Fig. 10** use two different braking systems. Discuss **three** main characteristics of disc brakes and **three** main characteristics of cantilever brakes. With reference to the bicycles shown below, justify the decision to use disc brakes on the mountain bike (**Fig. 9**) and cantilever brakes on the road bike (**Fig. 10**). [9 marks]

**Quality of written communication will be assessed in this question.**

**Fig. 9**



**Fig. 10**



Disc Brakes

---

---

---

---

---

---

---

---

---

---



---

---

---

---

---

---

---

(iv) During transportation to cycling races the bicycles are moved in team vans. Within the engine of the van the piston has a mass of 4.2 kg and moves at a speed of 1200 rpm. Calculate the kinetic energy of the piston if it reciprocates 60 mm during one complete stroke. [3 marks]

Answer \_\_\_\_\_ J

- (v) The power for the crankshaft shown in **Fig. 8** is 13.188 kW. Assuming no loss due to friction, calculate the output torque for the crankshaft if it rotates at 900 rpm. [2 marks]  
Assume  $\pi = 3.14$ .

Answer \_\_\_\_\_ Nm

- (vi) The bicycles shown in **Fig. 9** and **Fig. 10** use chain drives. Explain **two** main advantages of using chain drives over pulley drives for the transfer of motion in a bicycle. [2 marks for each]

1. \_\_\_\_\_

\_\_\_\_\_

\_\_\_\_\_

\_\_\_\_\_

2. \_\_\_\_\_

\_\_\_\_\_

\_\_\_\_\_

\_\_\_\_\_

- (b) (i) For the testing of mountain bike forks, a pneumatic system has been set up. Complete the circuit in **Fig. 11** to enable both double acting cylinders to be controlled with a high degree of positional accuracy using a single component operated by the 3/2 valves indicated. [3 marks]

**Fig. 11**

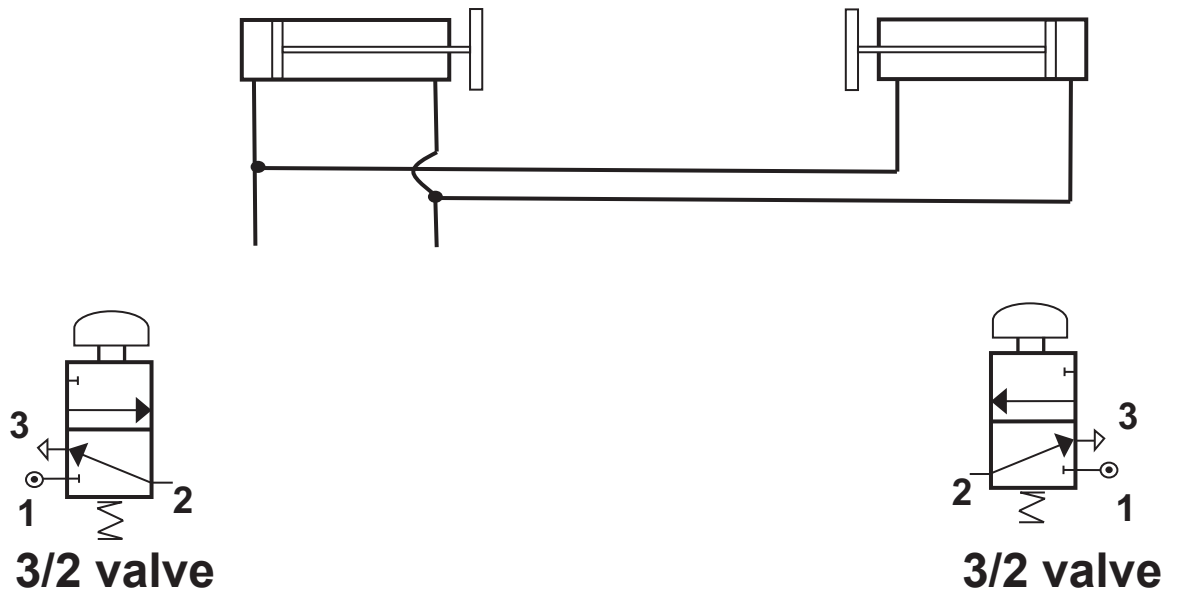

- (ii) The single acting cylinder shown in **Fig. 12** has a stroke length of 200 mm and produces an outstroke force of 820 N. Calculate the work done on the outstroke if it loses 20% through inefficiency. [2 marks]

**Fig. 12**



Answer \_\_\_\_\_

**Blank page**  
**(Questions continue overleaf)**

(c) **Fig. 13** shows an image of a customer using a car-fitted bicycle rack to transport bicycles for sport or leisure.

**Fig. 13**



- (i) Design and draw, in the space below **Fig. 14**, a mechanism to be attached to the indicated straps that will ensure the bicycle will not move during transportation. The chosen mechanism must be able to lock and unlock very quickly and should be located inside box A. [4 marks]

**Fig. 14**

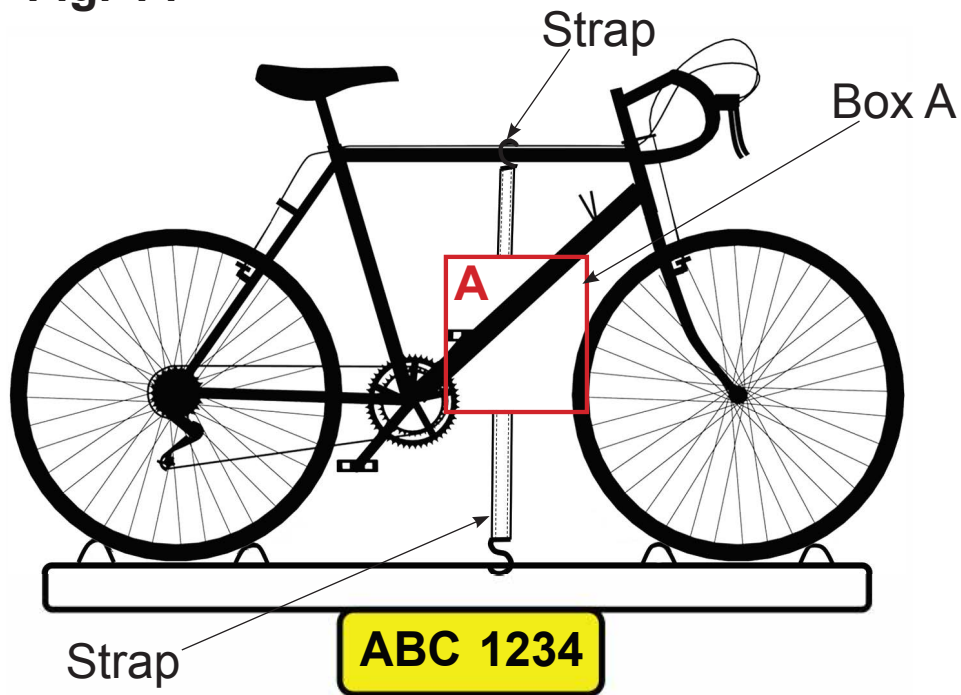

(ii) Complete the circuit in **Fig. 15** opposite to enable the attachment for the bicycle rack to the tow bar to be tested. This is to ensure it will clamp safely onto the car and comply with the required standard. Using microswitches A and B, your design must clamp onto the tow bar using the double acting cylinder and the clamping bars.

The circuit must be piped to ensure it has a safety switch so that the cylinder would not release during transit.

As the cylinder goes positive, the clamping bars will clamp onto the tow bar and, as they go negative, they will release from the tow bar. [6 marks]

**Fig. 15**

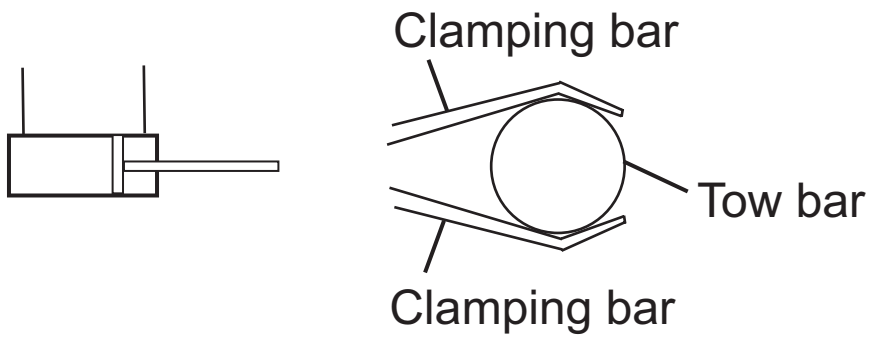
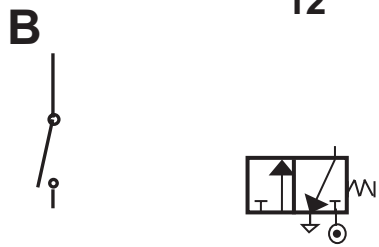
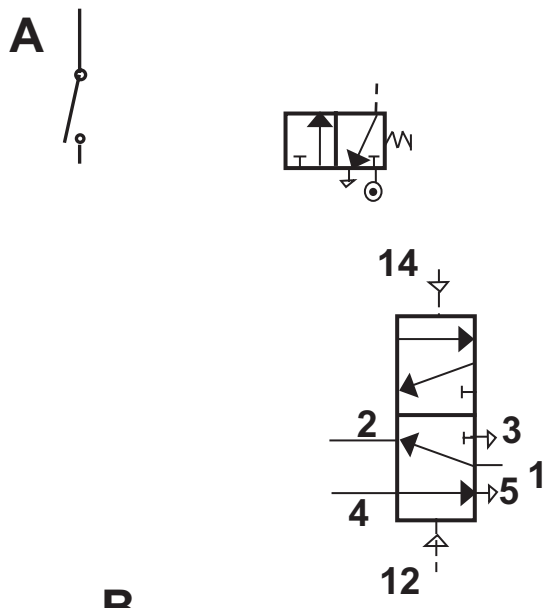

4 (a) (i) Draw an annotated sketch to show the pitch circle diameter and pitch point on a gear. [2 marks]

(ii) Explain the difference between pitch circle diameter and pitch point. [2 marks]

---

---

---

---

(b) (i) A forklift, similar to the one shown in **Fig. 16**, opposite is used to lift a range of heavy items. When lifting a container, calculate the gain of potential energy if the mass is 20 tonne and the vertical height is 20 m. Assume  $g = 9.82 \text{ m/s}^2$  and 1 tonne = 1000 kg. [2 marks]

**Fig. 16**



Answer \_\_\_\_\_ J

- (ii) The forklift in **Fig. 16** operates using a hoist. If the power is 600W, and the gravitational force on the pulley is 1000 N, calculate the time taken for the hoist to lift a cargo load over a vertical distance of 9 metres. Please ignore friction in your calculation. [2 marks]

Answer \_\_\_\_\_ s

- (iii) Many of the containers are stored in warehouses. The warehouse beams shown in **Fig. 17** are bolted to concrete slabs using a torque wrench. Calculate the depth of the torque wrench if a force of 300 N is applied and a torque of 100 Nm is produced. [2 marks]

**Fig. 17**

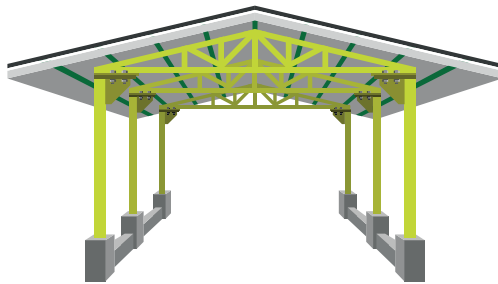

Answer \_\_\_\_\_ m

- (c) (i) Bags of compost are stored inside the containers. On **Fig. 18**, opposite complete the diagram activating a proximity sensor when the compost hopper is full. This will activate cylinder A to enable the compost bag to be stamped at the angle indicated with a suitable attachment using the pivot shown. Cylinder A must automatically instroke after the bag has been stamped. [5 marks]

**Fig. 18**

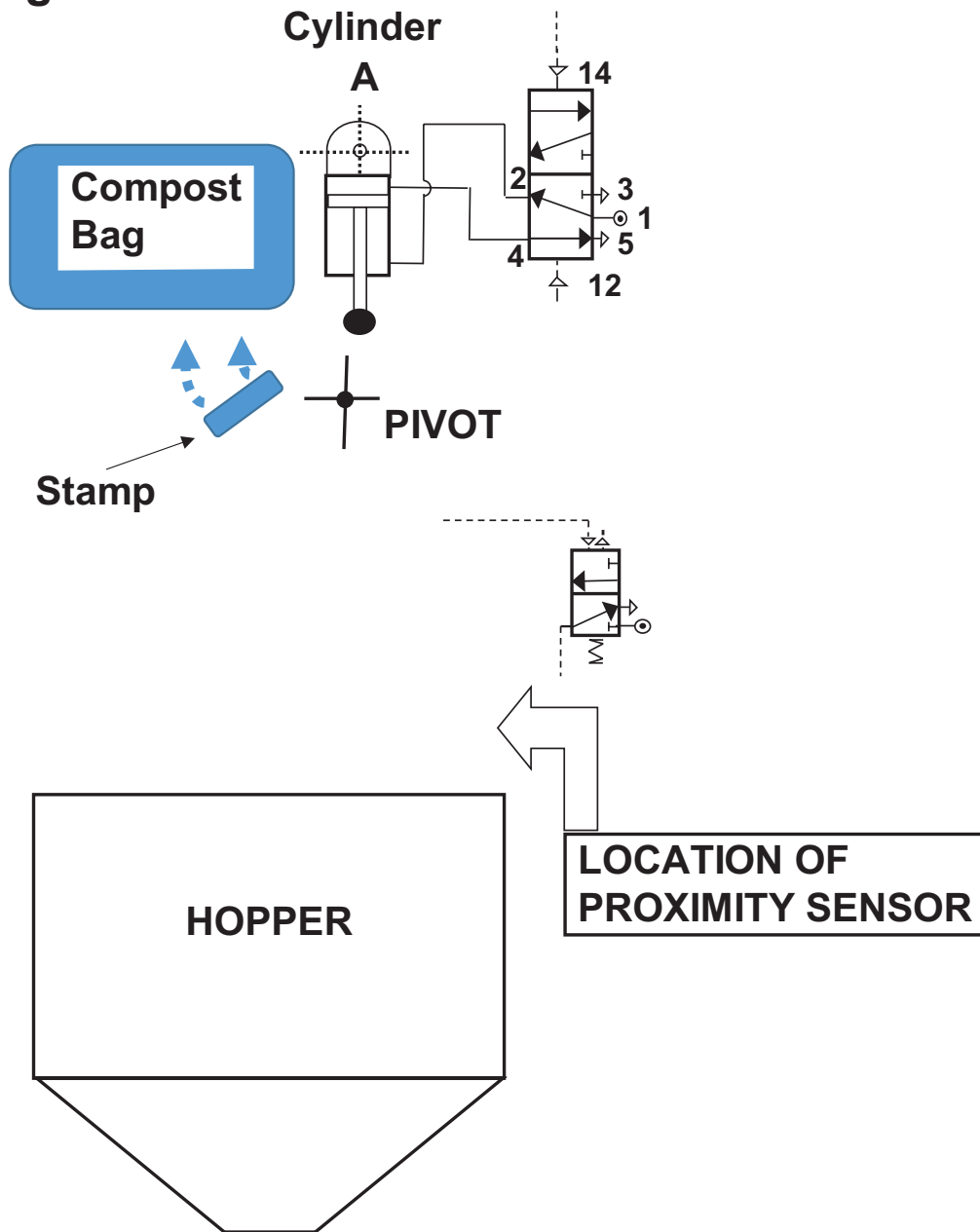

(ii) With reference to **Fig. 19**, select a piston rod, cylinder and air pressure in order to calculate the minimum and maximum force for a cylinder instroking and calculate the difference between them. Assume  $\pi = 3.14$ . [5 marks]

Available ( <b>d</b> ) piston rod sizes	Available ( <b>D</b> ) cylinder sizes	Available air pressure settings
8 mm	40 mm	3 bar
12 mm	52 mm	6 bar
16 mm	64 mm	9 bar

**Fig. 19**



Answer \_\_\_\_\_ N

**(d)** Inside the compost machinery production plant, a range of pneumatic systems are used. Complete the following sequence on the A3 pro forma (answer number **4(d)**) using the minimum number of groups. Some of the piping has been completed on the pro forma to assist you. The sequence begins: [10 marks]

- By closing either guard (A and B) or (C and D) Cylinder A goes positive.
- When Cylinder A is in the positive position it is detected by the air bleed.
- Cylinders B1 and B2 then go positive slowly. When Cylinder B2 is in the positive position it is detected by the 3/2 valve and sends Cylinders B1 and B2 negative.
- Following detection by the 3/2 valve Cylinder A then goes negative. Following detection by the microswitch Cylinder C then goes positive.
- After detection by the 3/2 valve Cylinder C goes negative. Following detection of Cylinder C in the negative position Cylinder D will go negative.
- Following detection by the air bleed Cylinder D will go positive to activate the 3/2 valve which repeats the sequence.

**(e)** On the pro forma provided (answer number **4(e)**) design, draw and annotate appropriate technical systems which would achieve the following requirements: [10 marks]

Operate Cylinder E to enable the cylinder to rotate the compost bag through 90 degrees for packaging reasons. A mechanism must be attached to the end of the cylinder to achieve this action.

Operate Cylinder F to push the compost bag down the conveyor belt as shown. A cam-based mechanism must be attached to the end of Cylinder F to push the compost bag on the positive stroke but not as the piston returns on the negative stroke.

All connections should be clearly indicated.

**Blank page**  
**(Questions continue overleaf)**

## Section C

### Product Design

Answer **both** questions in this section.

**Fig. 20**



**5** Hand tools, such as the spanners shown in **Fig. 20**, are important to the sales figures of any general hardware store. The development of these tools over the years may be described as being more incremental than radical.

**(a)** Distinguish between the terms incremental and radical when describing the development of these products.  
[2 marks]

---

---

---

---

(b) The introduction of new tools to the market may be as a result of technology push or through innovation in the market.

(i) Briefly outline **two** main factors associated with technology push. [1 mark for each]

1. \_\_\_\_\_

\_\_\_\_\_

2. \_\_\_\_\_

\_\_\_\_\_

(ii) Briefly outline **two** main reasons why it is so important to have innovation in the market. [1 mark for each]

1. \_\_\_\_\_

\_\_\_\_\_

2. \_\_\_\_\_

\_\_\_\_\_

(c) For companies designing and manufacturing hand tools, having an understanding of how market research can assist in the development of new or existing products is important.

Explain **two** different ways in which market research could be carried out to assist in the development of new or existing hand tools. [2 marks for each]

1. \_\_\_\_\_  
\_\_\_\_\_  
\_\_\_\_\_  
\_\_\_\_\_

2. \_\_\_\_\_  
\_\_\_\_\_  
\_\_\_\_\_  
\_\_\_\_\_

(d) Many hand tools have experienced an introduction, growth, maturity and decline phase during their life cycle.

Explain **two** main differences between the main characteristics of growth and the main characteristics of decline. [2 marks for each]

1. \_\_\_\_\_  
\_\_\_\_\_  
\_\_\_\_\_

2. \_\_\_\_\_  
\_\_\_\_\_  
\_\_\_\_\_

(e) For companies producing hand and machine tools, the issues regarding sustainability in the manufacture and disposal of many of the plastic components and housings continue to be a concern.

Briefly outline **three** main but different issues regarding sustainability in the manufacture or disposal of plastics. [1 mark for each]

1. \_\_\_\_\_  
\_\_\_\_\_

2. \_\_\_\_\_  
\_\_\_\_\_

3. \_\_\_\_\_  
\_\_\_\_\_

(f) In order to appeal to customers' environmental concerns, some companies have placed considerable emphasis on the concept of refuse in the 6R's and the possibility of using photodegradable plastic.

(i) Explain why it is so important for manufacturers to consider the concept of refuse in terms of the 6R's.  
[2 marks]

---

---

---

---

(ii) Explain what is meant by a photodegradable plastic.  
[2 marks]

---

---

---

---

(g) Companies who design and manufacture hand and machine tools need to have a knowledge and understanding of the four Ps.

For each of the following, explain **three** specific features that a company would need to have knowledge and understanding of in order to guide their business.  
[9 marks]





(h) The spanners shown in **Fig. 21** are to be housed and marketed as an 8 piece combination spanner set targeting the 'Do It Yourself' (DIY) Christmas or gift sector.

On the blank A3 pro forma (answer number **5(h)**) use detailed annotated sketches to produce **one** possible solution for the following:

**Fig. 21**

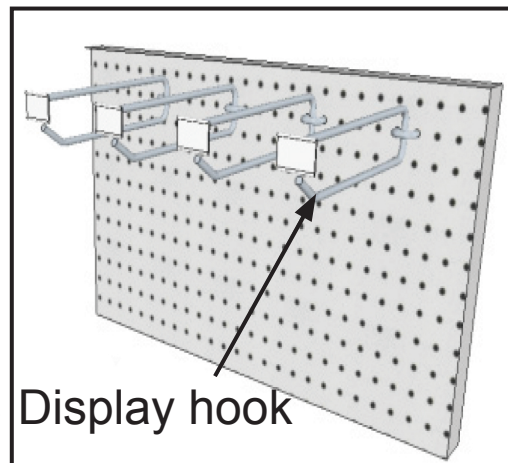

An appropriate design of a low cost compact storage unit that will securely house each of the 8 spanners shown in **Fig. 21**, whilst allowing the user to open the unit, remove a spanner, and then replace it before closing. Your design must be suitable to be placed on a shop aisle display hook as shown in **Fig. 21** and be easily carried by the consumer. [10 marks]

- 6 **Fig. 22** shows a photograph of a garden solar light. This is a low cost, lightweight and weather-resistant product which can light up garden pathways and flower beds.

**Fig. 22**



- (a) Understanding the concept elasticity of demand is important for companies who design and manufacture garden products.

With reference to a product of your choice, explain the concept elasticity of demand. [2 marks]

---

---

---

---

(b) The masses and late adopters are two types of consumers who emerge at each stage of the life cycle of a product.

(i) Briefly outline **two** main characteristics associated with the masses. [1 mark for each]

1. \_\_\_\_\_

\_\_\_\_\_

\_\_\_\_\_

2. \_\_\_\_\_

\_\_\_\_\_

\_\_\_\_\_

(ii) Briefly outline **two** main characteristics associated with late adopters. [1 mark for each]

1. \_\_\_\_\_

\_\_\_\_\_

\_\_\_\_\_

2. \_\_\_\_\_

\_\_\_\_\_

\_\_\_\_\_

(c) Designers and manufacturers need to give serious consideration to the environmental impact that a product has during its life cycle. This life cycle involves, firstly the extraction of materials needed for the product, secondly the processing of these materials, thirdly the manufacture of the product, fourthly the distribution of the product, fifthly the use of the product and finally the end of life considerations.

With reference to a product or products of your choice, explain the environmental impact that the following **three** stages of the life cycle may have on the design of your chosen example. [2 marks for each]

Extraction of materials \_\_\_\_\_

---

---

---

The use of the product \_\_\_\_\_

---

---

---

End of life considerations \_\_\_\_\_

---

---

---

(d) A report into the practices of the company manufacturing garden solar-based products made reference to embodied energy when considering sustainability and the reasons why the Kanban system should be adopted to manufacture their products.

(i) Explain what is meant by embodied energy when considering sustainability. [2 marks]

---

---

---

---

(ii) Explain **one** main reason for adopting the Kanban system. [2 marks]

---

---

---

---

(e) The use of jigs and templates is an important element of Quality Control (QC) when manufacturing garden solar-based products.

(i) With reference to a product of your choice, explain how jigs are employed to assist QC. [2 marks]

---

---

---

---

(ii) With reference to a product of your choice, explain how templates are employed to assist QC.  
[2 marks]

---

---

---

---

(f) When addressing environmental issues, the European Union (EU) has influenced the design of products.

Explain, with the use of **two** different examples, how the European Union (EU) has influenced the design of products whilst addressing environmental issues.  
[2 marks for each]

1. \_\_\_\_\_

---

---

2. \_\_\_\_\_

---

---

**(g)** The design and manufacture of a product can be influenced by ethnic and environmental factors.

**(i)** Describe **one** example of how the design or manufacture of a product has been influenced by ethnic factors. [2 marks]

---

---

---

---

**(ii)** Using a different example describe a product that incorporates environmental factors. [2 marks]

---

---

---

**(h)** The design of a number of products has been influenced by the work of Trevor Baylis.

Outline **two** characteristics which describe the influence of Trevor Baylis in terms of product design.

[1 mark for each]

1. \_\_\_\_\_

---

2. \_\_\_\_\_

---

(i) **Fig. 23** below shows a number of photographs of the garden solar light. During trials of this product, feedback from a consumer panel made a number of suggestions to improve the product. One suggestion was to make changes to the ground spike to make it easier for users to force the spike into the ground to the required depth. A second suggestion was to provide a wall mounted bracket so that this product could be used as a wall light.

**Fig. 23**

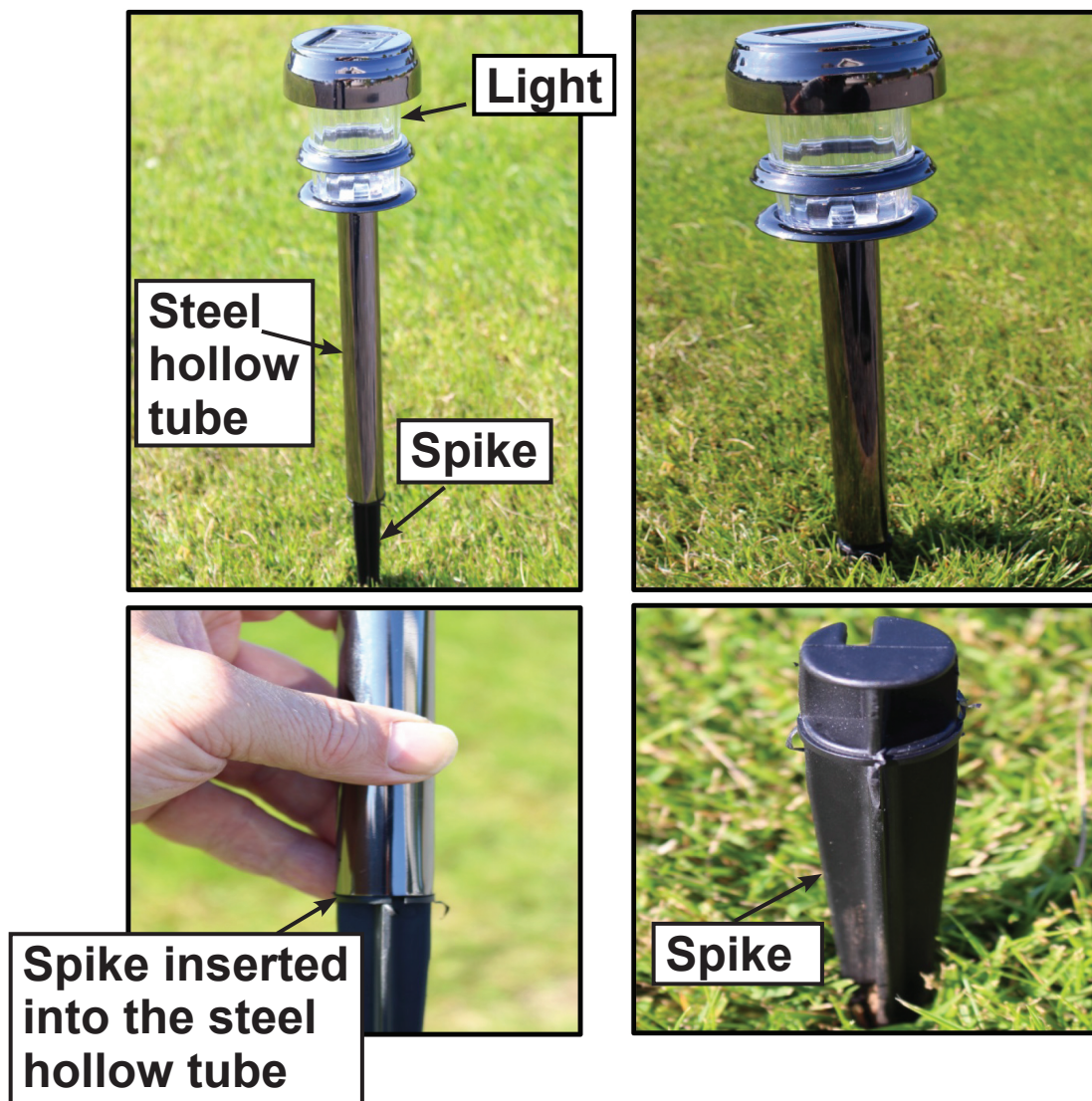

With reference to **Fig. 23** and on the blank A3 pro forma (answer number **6(i)(i) and (ii)**) use detailed annotated sketches to produce **one** possible solution for the following:

- (i) An appropriate design that would make it easier for users to force the spike into the ground to the required depth without the use of hand tools. Your design should be suitably attached or stored on the product to prevent loss when not in use.  
[4 marks]
  
- (ii) A low cost design of a wall mounted bracket that would allow the user to secure the solar light to a wall. Your design must allow the user to quickly make adjustments to the height of the light.  
[6 marks]

---

**This is the end of the question paper**

---

**SOURCES:**

Q1(a) .....Fig. 1 Source: CCEA

Q1(d) .....Fig. 3 Source: CCEA

Q2(a) .....Fig. 4 Source: CCEA

Q2(b) .....Fig. 5 Source: CCEA

Q2(c) .....Fig. 7 Source: CCEA

Q3(a)(ii) . Fig. 8 © Getty Images

Q3(a)(iii) .Fig. 9 and Fig. 10 © Getty Images

Q3(c) .....Fig. 13 © Getty Images

Q3(c)(i) ...Fig. 14 © Getty Images

Q4(b)(i) ...Fig. 16 © Getty Images

Q4(b)(iii) .Fig. 17 © Getty Images

For Examiner's use only	
Question Number	Marks
1	
2	
3	
4	
5	
6	
<b>Total Marks</b>	

Permission to reproduce all copyright material has been applied for.

In some cases, efforts to contact copyright holders may have been unsuccessful and CCEA will be happy to rectify any omissions of acknowledgement in future if notified.

Question No. 4(d)

Advanced (A2) Technology and Design  
Assessment Unit A2 1

Centre Number

--	--	--	--

Candidate Number

--	--	--	--

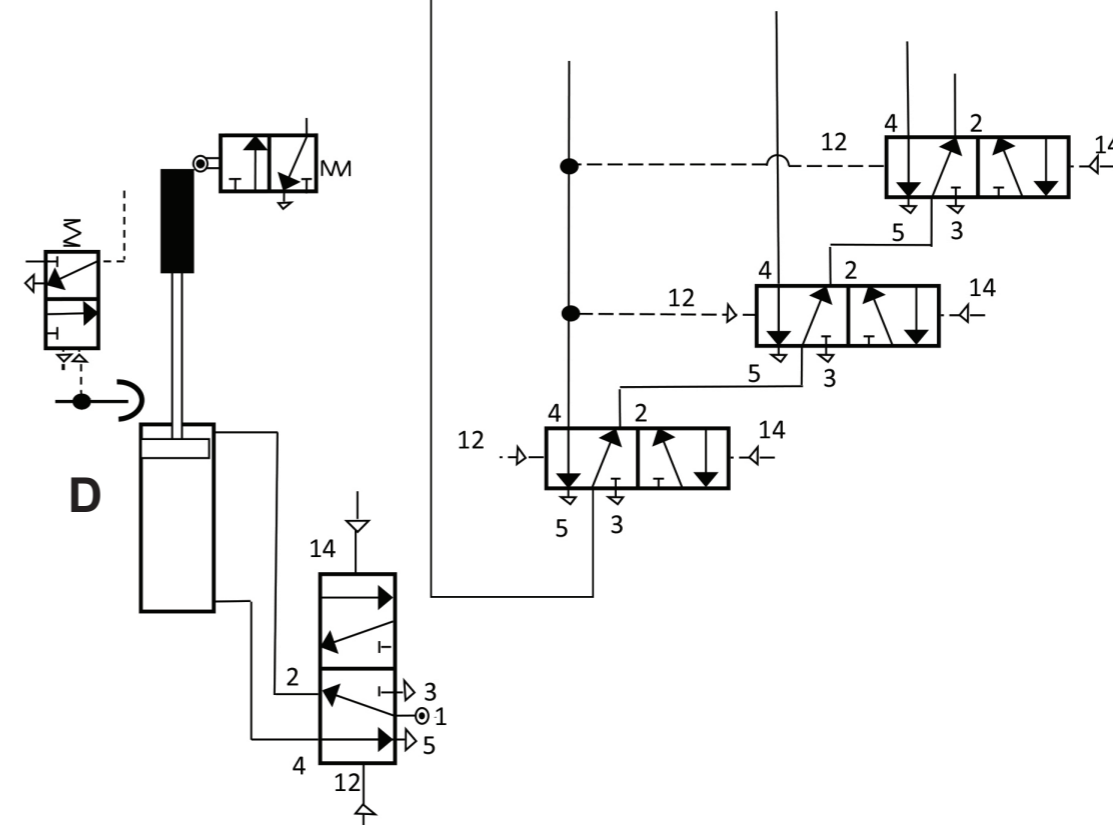
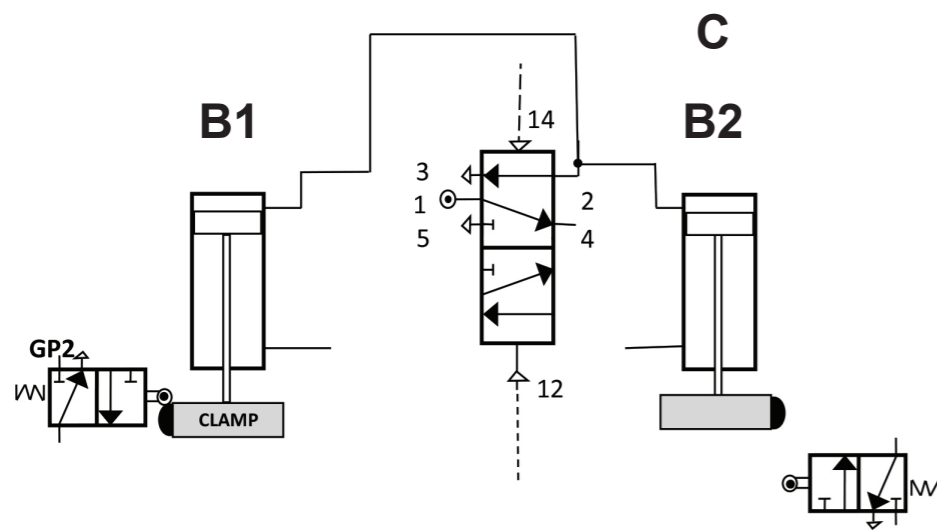
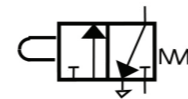
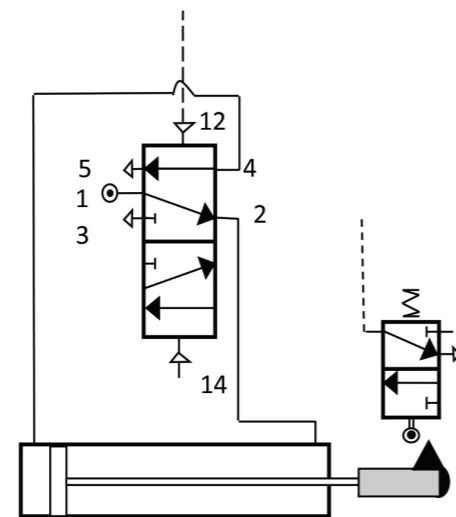
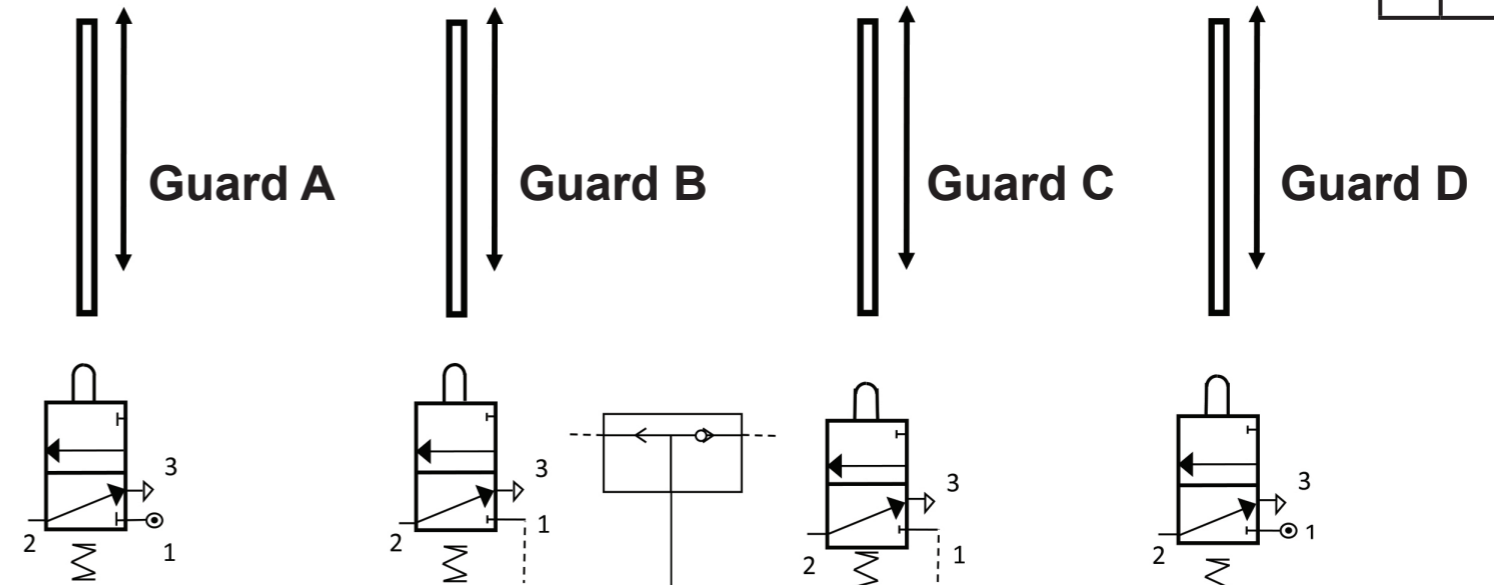
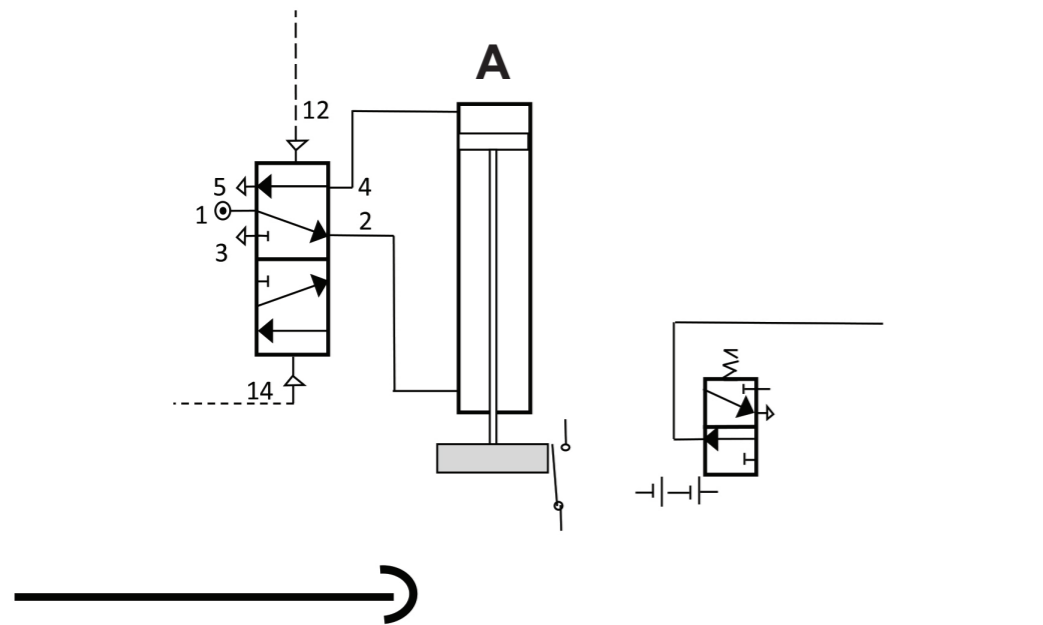

Pro forma answer page  
(answer number 4(d))

--	--	--	--	--

--	--	--	--

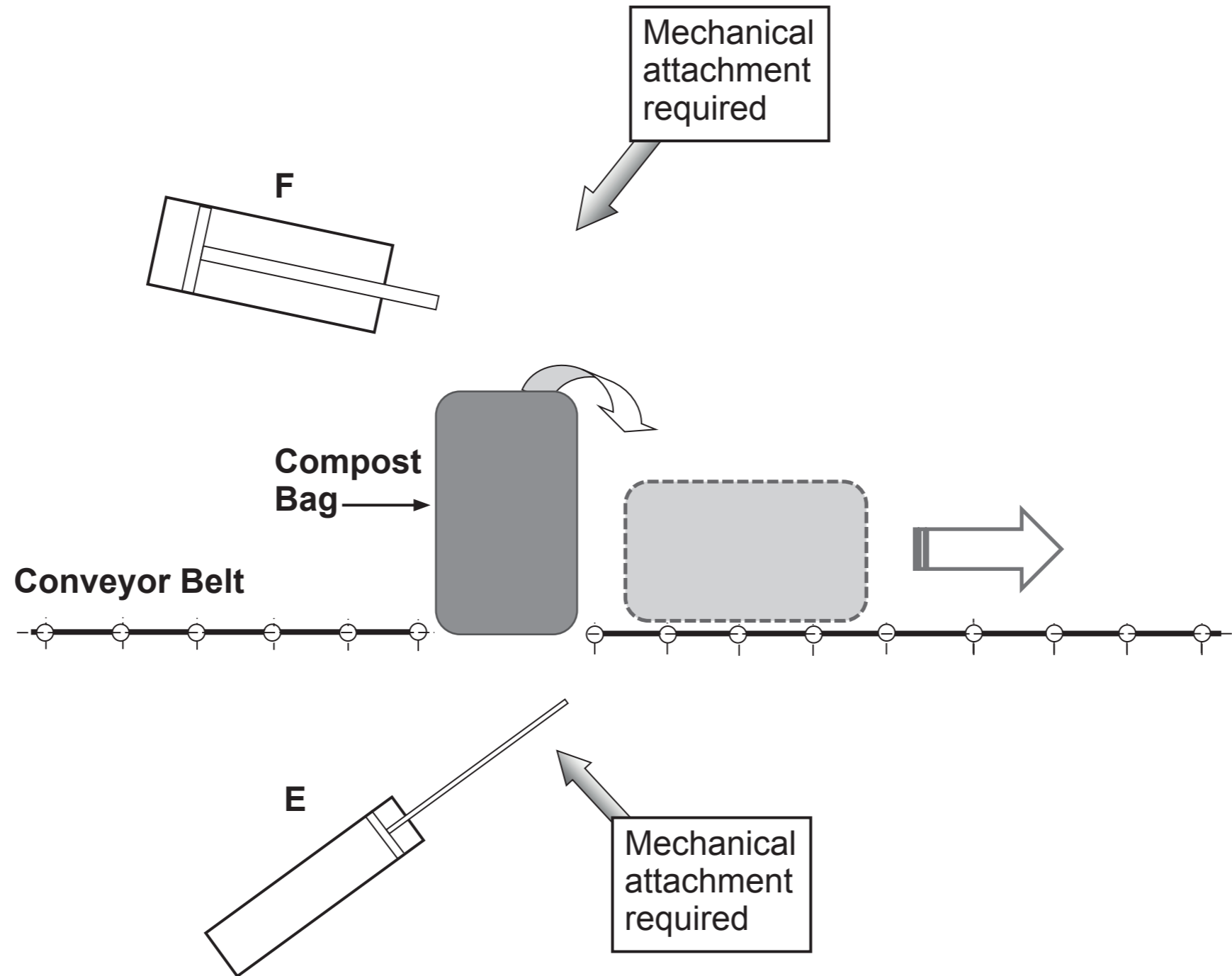

**Question No. 5(h)**

**Advanced (A2) Technology and Design  
Assessment Unit A2 1**

**Centre Number**

--	--	--	--	--

**Candidate Number**

--	--	--	--

**Pro forma answer page  
(answer number 5(h))**

**Question No. 6(i)(i) and (ii)**

**Advanced (A2) Technology and Design  
Assessment Unit A2 1**

**Centre Number**

--	--	--	--	--

**Candidate Number**

--	--	--	--

**Pro forma answer page  
(answer number 6(i)(i) and (ii))**